

FPD-XX24-12CD FIBERER DWDM 1.25G SFP Optical Transceiver

Features

- ◆ Wavelength selectable to C-band ITU-T grid wavelengths
- ◆ Suitable for use in 100GHz channel spacing DWDM systems
- ◆ DWDM SFP MSA Compliant
- ◆ Dual data-rate of 1.25Gbps/1.063Gbps operation
- ◆ OC-24 120km range
- ◆ Up to 2.67Gb/s data rate
- ◆ Cold Start up Wavelength Compliance
- ◆ Low Power Dissipation <1.3W Maximum
- ◆ -5°C to 70°C Operating Case Temperature
- ◆ Diagnostic Performance Monitoring of module temperature, supply Voltages, laser bias current, transmit optical power, receive optical power, Laser temperature and TEC current
- ◆ Extended link budget with APD receiver technology
- ◆ RoHS compliant and lead free 



Applications

- ◆ SFP Transceivers for DWDM SONET/ SDH
- ◆ Ethernet IEEE 802.3ae
- ◆ Fiber Channel

Description

FIBERER DWDM SFP Transceiver exhibits excellent wavelength stability, supporting operation at 100 GHz channel, cost effective module. It is designed for DWDM SONET/ SDH, Gigabit Ethernet and Fiber-Channel applications.

The transceiver consists of two sections: The transmitter section incorporates a colded DFB laser. And the receiver section consists of a APD photodiode integrated with a TIA. All modules satisfy class I laser safety requirements. FIBERER DWDM SFP transceiver provides an enhanced monitoring interface, which allows real-time access to device operating parameters such as transceiver temperature, laser bias current, transmitted optical power, received optical power and transceiver supply voltage, laser temperature and TEC



current.

Absolute Maximum Ratings

Parameter	Symbol	Min	Max	Unit
Supply Voltage	Vcc	-0.3	4.0	V
Storage Temperature	Tst	-40	85	°C
Data AC Voltage	TX+-AC	-	2.4	Vpp
Data DC Voltage	TX+-DC	-0.5	2.5	V
Optical Input Received Power	PIN	-	+5	dBm

Operating Conditions

Parameter	Symbol	Min	Typical	Max	Unit
Supply Voltage	Vcc	3.13	3.3	3.47	V
Operating Case temperature	Tca	-5	-	70	°C
Total Current	Icc	-	-	380	mA
Module Power Dissipation	Pm	-	0.8	1.3	W

Transmitter Specifications – Optical

Parameter	Symbol	Min	Typical	Max	Unit
Data Rate Multirate	Mra	155		2667	Mbps
Center Wavelength (SOL)△	λ_c	$\lambda_c - 25$	λ_c	$\lambda_c + 25$	pm
Center Wavelength (EOL)▲	λ_c	$\lambda_c - 100$	λ_c	$\lambda_c + 100$	pm
Optical Transmit Power	Po	0	2	4	dBm
Optical Transmit Power (disabled)	PTX_DISABLE	-	-	-40	dBm
Extinction Ratio	ER	8.2		-	dB
Channel Spacing	Δf	-	100	-	GHz
Jitter Generation	TJP-P	-	-	70	mUI
Spectral Width (-20dB)	DI20	-	0.1	0.3	nm
Side Mode Suppression Ratio	SMSR	30	-	-	dB
Eye Mask	Compliant with Bell core GR-253-CORE & ITU G.957 for SONET/SDH and with IEEE 802.3ae for Ethernet and Fibre Channel				

△Laser- Start of Life

▲Laser End of life

Transmitter Specifications – Electrical

Parameter	Symbol	Min	Typical	Max	Unit
Supply Voltage	VccTX	3.13	3.3	3.47	V
PECL/CML Input	VtxDIFF	500	-	1600	mV
Input Rise/Fall	TR / TF	-	-	160	ps
TX-Fault Fault	Vf	2	-	Vcc	V
TX-Fault Normal	Vn	Vee	-	Vee+0.5	V
TX_DISABLE (asserted)	VDH	2	-	Vcc	V



TX_DISABLE (negated)	VDL	Vee	-	Vee+0.8	V
----------------------	-----	-----	---	---------	---

APD Receiver Specifications – Optical

Parameter	Symbol	Min	Typical	Max	Unit
Receiver Sensitivity (OC3/OC24)		-	-32	-30	dBm
Maximum Input Power	RX-overload	-9	-	-	dBm
Input Operating Wavelength	λ	1528	-	1564	nm
Reflectance	Rrx	-	-	-27	dB
Loss of Signal Asserted		-40	-	-	dBm
LOS De-Asserted		-	-	-32	dBm
LOS Hysteresis		0.5	-	-	dB

APD Receiver Specifications – Electrical

Parameter	Symbol	Min	Typical	Max	Unit
Supply Voltage	VccRX	3.13	3.3	3.47	V
Differential Output Swing	Vout P-P	370	-	2000	mV
Rise/Fall Time	Tr / Tf	-	-	175	ps
Loss of Signal –Asserted	VOH	2	-	Vcc	V
Loss of Signal –Negated	VOL	Vee	-	Vee+0.5	V

Low Speed Electrical Signal Timings

Parameter	Symbol	Min	Typical	Max	Unit
TX Disable Negate Time	t-on	-	-	20	ms
TX Disable Assert Time	t-off	-	-	20	ms
Time to initialize, including reset of TX_FAULT	t_init	-	-	300	ms
Start-up Time	t_startup	-	-	90	s
TX_FAULT/INT Assert Time	t_fault	-	-	50	ms
TX_DISABLE to Reset	t_reset	10	-	-	ms
LOS Assert Time	t_los_on	-	-	100	us
LOS Negate Time	t_los_off	-	-	100	us
Serial ID Clock Rate	f_serial_clock	-	-	100	kHz

C-band λ_c Wavelength Guide



ITU Channel Product Code	Frequency(THz)	Wavelength	ITU Channel Product Code	Frequency(THz)	Wavelength
17	191.7	1563.86	40	194.0	1545.32
18	191.8	1563.05	41	194.1	1544.53
19	191.9	1562.23	42	194.2	1543.73
20	192.0	1561.42	43	194.3	1542.94
21	192.1	1560.61	44	194.4	1542.14
22	192.2	1559.79	45	194.5	1541.35
23	192.3	1558.98	46	194.6	1540.56
24	192.4	1558.17	47	194.7	1539.77
25	192.5	1557.36	48	194.8	1538.98
26	192.6	1556.55	49	194.9	1538.19
27	192.7	1555.75	50	195.0	1537.40
28	192.8	1554.94	51	195.1	1536.61
29	192.9	1554.13	52	195.2	1535.82
30	193.0	1553.33	53	195.3	1535.04
31	193.1	1552.52	54	195.4	1534.25
32	193.2	1551.72	55	195.5	1533.47
33	193.3	1550.92	56	195.6	1532.68
34	193.4	1550.12	57	195.7	1531.90
35	193.5	1549.32	58	195.8	1531.12
36	193.6	1548.51	59	195.9	1530.33
37	193.7	1547.72	60	196.0	1529.55
38	193.8	1546.92	61	196.1	1528.77
39	193.9	1546.12			

Serial ID Memory Contents: (A2H)

Address	# Bytes	Name	Description
---------	---------	------	-------------



00-55	56	Alarm and Warning Levels	Temp/ Vcc/ Bias Current /TX Power/ RX Power/ LD Temp/ TEC Current, High/Low Alarm and Warning Levels
56-94	39		Not used in DWDM devices. All Bytes Set to 0.
95	1	Checksum	Low order 8 bits of the sum of bytes 0-94
96-109	8	A/D Values	A/D binary values of the following enhanced diagnostics(Real-time): module temperature, supply voltage, laser bias current, transmit optical power, receive optical power, laser temperature and TEC current. These values are Internally calibrated absolute measurements. All diagnostic parameters implemented in these address locations have a corresponding high and low, alarm and warning thresholds assigned in address locations 00-55.
110	1	Soft Control Signals	Soft control signals monitored over the 2-wire access port. can updated real-time status of the following control signals: TX_FAULT, TX_DISABLE, Rate Select, and LOS.
111	1	Reserved	Reserved
112-117	5	Alarm/Warning Flags	Optional Alarm and Warning Flag and Mask Bits Corresponding to levels detailed in addresses 00-39 above.
118-119	2	Warning Mask	Masking bits corresponding to Warning bits of bytes 116 and 117 respectively
120-126	8	Vendor Specific	Vendor specific data
127	1	Table Select	The byte value defines the Table location for subsequent reads and writes to bytes locations 128-255
128-247	120	User EEPROM	User writable EEPROM
248-255	8	Vendor Specific	Vendor specific control functions

Digital Diagnostic Monitoring A/D Accuracy

Parameter	Range	Accuracy	Unit
Temperature	-40~100	± 3	°C
Voltage	0~Vcc	0.1	V
Bias Current	0~120	5	mA
TX Power	0~5	± 2	dBm
RX Power	-32~-8	± 2	dBm
TEC Current	-1200~1200	± 65	mA
LD Temperature	20~70	± 0.25	°C

Pin Definitions

Pin Number	Name	Function	Ref.
1	VEET	Transmitter Ground	
2	TX_FAULT/INT	Transmitter Fault	1
3	TX_DISABLE	Transmitter Disable	2
4	MOD-DEF(2)	Module Definition 2	3
5	MOD-DEF(1)	Module Definition 1	3
6	MOD-DEF(0)	Module Definition 0	3
7	Tone in	Rate Select -Not Implemented	
8	LOS	Loss of Signal	4

9	VEER	Receiver Ground	
10	VEER	Receiver Ground	
11	VEER	Receiver Ground	
12	RD-	Inverted Received	
13	RD+	Received Data	
14	VEER	Receiver Ground	
15	VCCR	Receiver Power	
16	VCCT	Transmitter Power	
17	VEET	Transmitter Ground	
18	TD+	Transmit Data	
19	TD-	Inverted Transmit	
20	VEET	Transmitter Ground	

Notes:

1. TX Fault is an open collector/drain output, which should be pulled up with a 4.7K – 10K. resistor on the host board. Pull up voltage between 2.0V and VccT, R+0.3V. When high, output indicates a laser fault of some kind. Low indicates normal operation. In the low state, the output will be pulled to < 0.8V.
2. TX disable is an input that is used to shut down the transmitter optical output. It is pulled up within the module with a 4.7 – 10 K. resistor.
3. These are the module definition pins. They should be pulled up with a 4.7K – 10K. resistor on the host board. The pull-up voltage shall be VccT or VccR (see Section IV for further details).
4. LOS (Loss of Signal) is an open collector/drain output, which should be pulled up with a 4.7K – 10K. resistor. Pull up voltage between 2.0V and VccT, R+0.3V. When high, this output indicates the received optical power is below the worst-case receiver sensitivity (as defined by the standard in use). Low indicates normal operation. In the low state, the output will be pulled to < 0.8V.

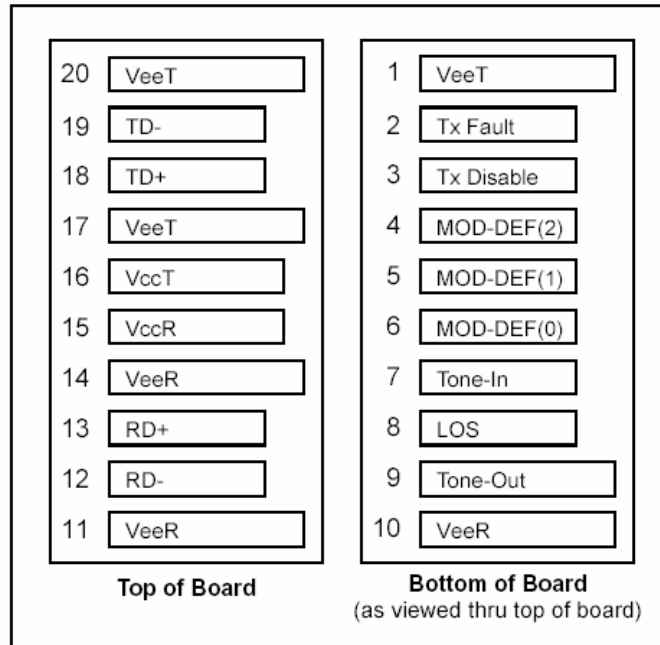

Figure1.Electrical Pin-out Details

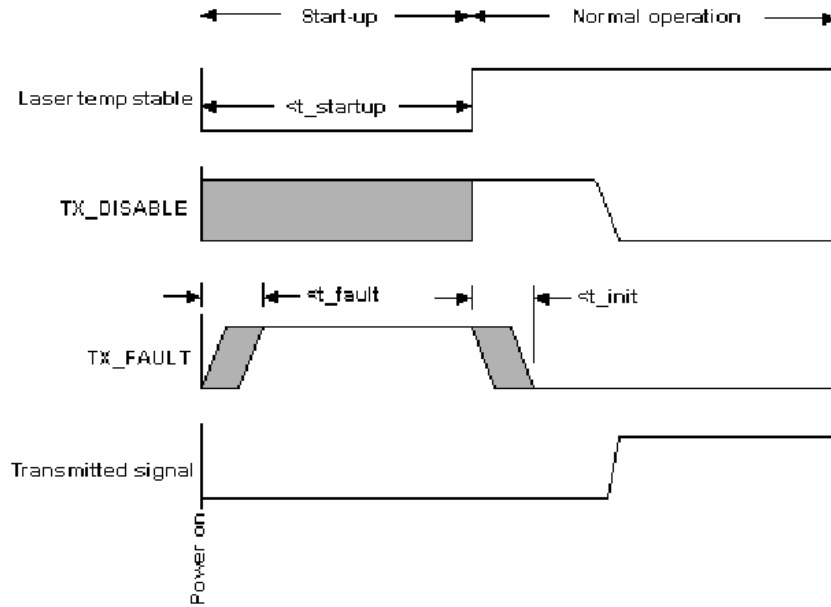

Figure2. Power-on initialisation of DWDM SFP transceiver

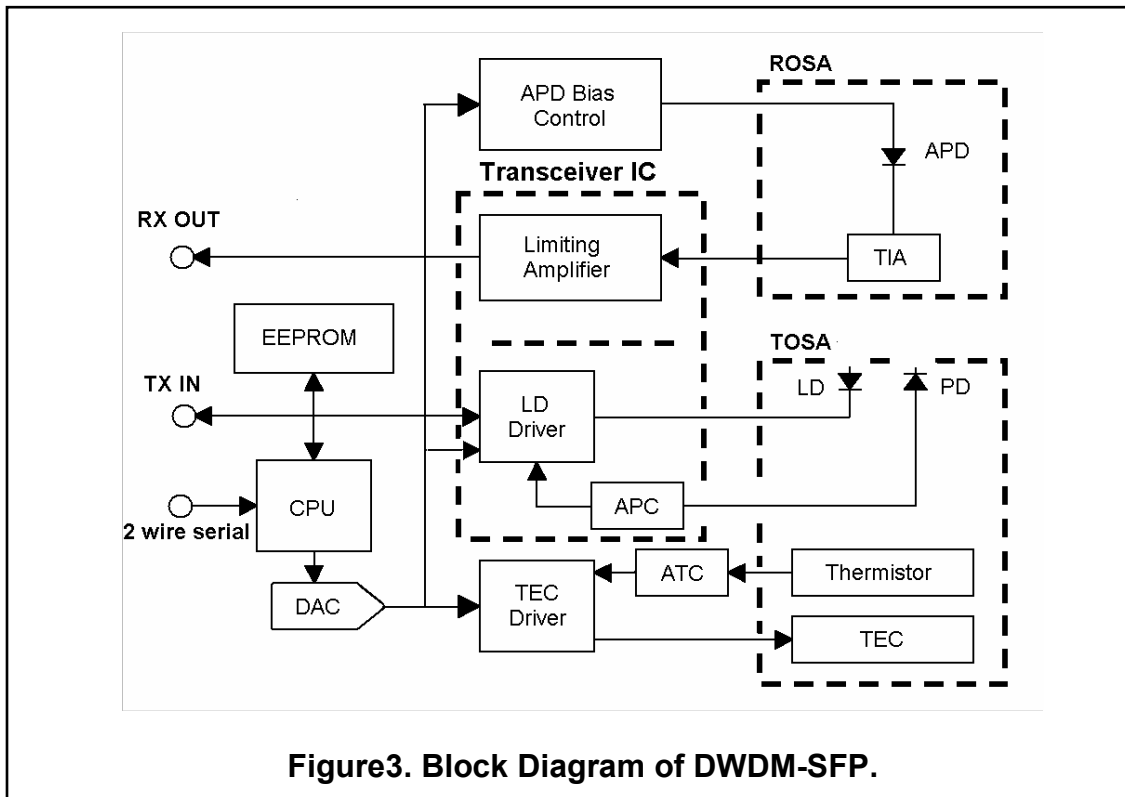

Figure3. Block Diagram of DWDM-SFP.

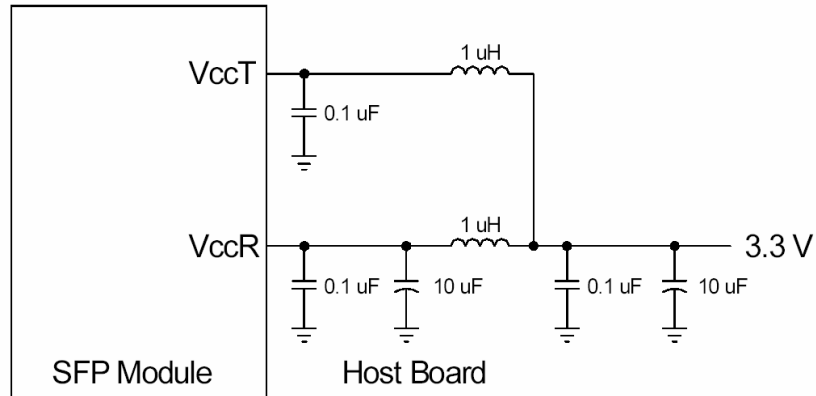

Figure4. Recommended Host Board Supply Filtering Network

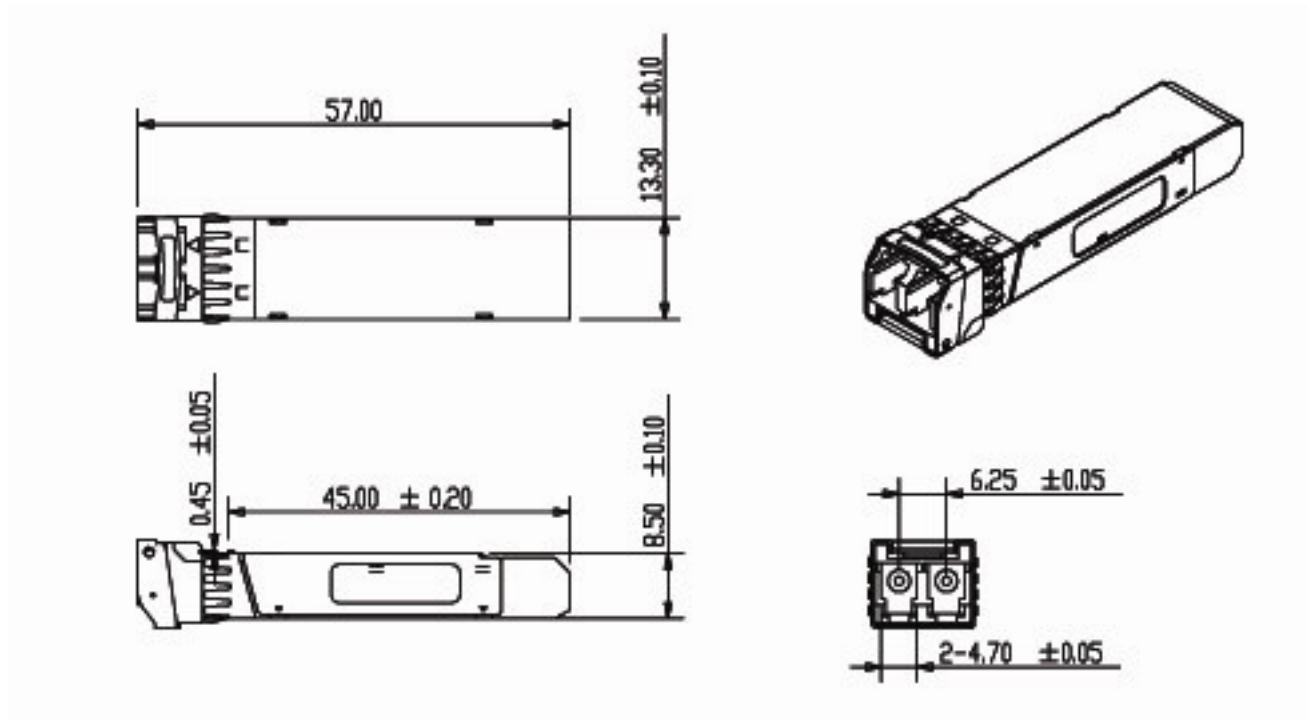

Figure5. Mechanical Dimensions



Regulatory Compliance

FIBERER SFP-DWDM transceiver is designed to be Class I Laser safety compliant and is certified per the following standards:

Feature	Agency	Standard	Certificate / Comments
Laser Safety	FDA	CDRH 21 CFR 1040 annd Laser Notice No. 50	1120288-000
Product Safety	BST	EN 60825-1: 2007 EN 60825-2: 2004 EN 60950-1: 2006	BST09082331721C-2
Environmental protection	CCIC	RoHS Directive 2002/95/EC	RET090616001
EMC	WALTEK	EN 55022:2006+A1:2007 EN 55024:1998+A1+A2:2003 -	WT10093768-D-E-E

Ordering information

Part Number	Product Description
FPD-XX24-12CD	DWDM SFP, XX=17~61 (ITU Channel C-band), 1.25Gbps, 120km, -5°C ~ +70°C, Digital Diagnostic Monitoring

References

1. Small Form Factor Pluggable Module (SFP) Multi-Source Agreement (MSA), September 2000.
2. IEEE802.3ae – 2002
3. Telcordia GR-253-CORE
4. “Diagnostic Monitoring Interface for Optical Transceivers” SFF-8472, Rev 9.3.

Important Notice

Performance figures, data and any illustrative material provided in this data sheet are typical and must be specifically confirmed in writing by FIBERER before they become applicable to any particular order or contract. In accordance with the FIBERER policy of continuous improvement specifications may change without notice.

The publication of information in this data sheet does not imply freedom from patent or other protective rights of FIBERER or others. Further details are available from any FIBERER sales representative.

Copyright@ Fiberer Global Tech Ltd.

OurSpiritual Mission

To facilitate User's network and testing systems more successful,let the world more beautiful by our high quality and



Fiberer Global Tech Ltd
engineer@fiberer.com

Not only high quality...
www.sfp-module.com

stability of products and VIP service.

Production Capacity

The quantity of our staff is more than 2,800 and the workshop area is 6,000 square meters. We have a 10,000 level of purifications production workshop about 3000 square meters, and the production capacity is above 5000pcs/week on fiber-optic modules and components.

Email: engineer@fiberer.com

Website: <http://www.sfp-module.com>