FBPXXXX192-ERC

10Gbps SFP+ Bi-Directional Transceiver, 40km Reach
1270/1330nm TX / 1330/1270 nm RX

Features

- ◆ Supports 9.95Gb/s to 10.3Gb/s data rates
- ◆ Simplex LC Connector Bi-Directional SFP+ Optical Transceiver
- ◆ Single 3.3V Supply
- ◆ Up to 40km on 9/125um SMF
- ◆ A:1270nm DFB Laser transmitter,1330nm receiver
B:1330nm DFB Laser transmitter,1270nm receiver
- ◆ SFP+ MSA SFFBP8431 Compliant
- ◆ Digital Diagnostic SFFBP8472 Compliant
- ◆ RoHS compliant and Lead Free
- ◆ Operating case temperature:
Standard: 0 ~ 70 °C

Applications

- ◆ 10GBASE-ER at 10.3125Gbps
- ◆ 10GBASE-EW at 9.953Gbps
- ◆ Other Optical Links

Product description

The GBP-XXXX192-ERC series single mode transceiver is small form factor pluggable module for duplex optical data communications such as 10GBASE-ER/EW defined by IEEE 802.3ae. It is with the SFP+ 20-pin connector to allow hot plug capability.

The GBP-XXXX192-ERC module is designed for single mode fiber and operates at a nominal wavelength of 1270nm or 1330nm;.The transmitter section uses a multiple quantum well DFB, which is class 1 laser compliant according to International Safety Standard IEC-60825.The receiver section uses an integrated InGaAs detector preamplifier (IDP) mounted in an optical header and a limiting post-amplifier IC.

Absolute Maximum Ratings

These values represent the damage threshold of the module. Stress in excess of any of the individual

Absolute Maximum Ratings can cause immediate catastrophic damage to the module even if all other parameters are within Recommended Operating Conditions.

Parameters	Symbol	Min.	Max.	Unit
Supply Voltage	V _{CC}	-0.5	+3.6	V
Storage Temperature	T _c	-40	+85	°C
Operating Case Temperature	T _c	0	+70	°C
Relative Humidity	RH	0	85	%

Recommended Operating Conditions

Parameter	Symbol	Min.	Typical	Max	Unit
Supply Voltage	V _{CC}	3.0	3.3	3.6	V
Supply Current	I _{CC}		300	450	mA
Operating Case Temperature	T _C	0	25	70	°C
Module Power Dissipation	P _m	-	1	1.5	W

Notes:

[1] Supply current is shared between VCCTX and VCCR_X.

[2] In-rush is defined as current level above steady state current requirements.

Electrical characteristics(T_{OP} = 0 to 70°C, V_{CC} = 3.0 to 3.60 Volts)

Parameter	Symbol	Min.	Typical	Max	Unit	Ref.
Supply Voltage	V _{CC}	3.00		3.60	V	1
Supply Current	I _{CC}		300	450	mA	1
Transmitter						
Input differential impedance	R _{in}		100		Ω	2
Single ended data input swing	V _{in,pp}	150		1200	mVpp	
Transmit Disable Voltage	V _D	2		V _{CC}	V	
Transmit Enable Voltage	V _{EN}	V _{ee}		V _{ee} +0.8	V	3
Receiver						
Output differential impedance	R _{out}		100		Ω	2
Single ended data output swing	V _{out,pp}	300		700	mV	4
LOS Fault	V _{LOS fault}	2		V _{CCHOST}	V	5
LOS Normal	V _{LOS norm}	V _{ee}		V _{ee} +0.8	V	5

Notes:

1. Module power consumption never exceeds 1W.
2. AC coupled.

3. Or open circuit.
4. Into 100 ohm differential termination.
5. LOS is LVTTTL. Logic 0 indicates normal operation; logic 1 indicates no signal detected.

Optical characteristics($T_{OP} = 0$ to $70^{\circ}C$, $V_{CC} = 3.0$ to 3.60 Volts)
(FBP2733192-ERC, 1270 DFB & PIN/TIA)

Parameter	Symbol	Min.	Typical	Max	Unit	Ref.
Transmitter						
Optical Wavelength	λ_c	1260	1270	1280	nm	
Side Mode Suppress Ratio	SMSR	30			dB	
Spectral Width(-20dB)	$\Delta\lambda$			1	nm	
Average Output Power	P_{op}	1		5	dBm	1
Extinction Ratio	ER	3.5			dB	
Eye Mask		Compliant with IEEE 802.3				
Transmitter and Dispersion Penalty	TDP			3.2	dB	
Average Power of OFF Transmitter				-30	dBm	
Relative Intensity Noise	RIN			-128	dB/Hz	
Receiver						
Average Receiver Power	RSENS			-15	dBm	1,2
Receiver Overload	P_{MAX}			+0.5	dBm	
Centre Wavelength	λ_C	1320		1340	nm	
LOS De-Assert	LOS_D			-15	dBm	
LOS Assert	LOS_A	-30			dBm	
LOS Hysteresis		0.5			dB	

Notes:

1. Average Receiver Power (Min) is informative and not the principal indicator of signal strength. A received power below this value cannot be compliant.
2. Measured with a PRBS2³¹-1 test pattern @10.3125Gbps, BER \leq 10-12

(FBP3327192-ERC, 1330 DFB & PIN/TIA)

Parameter	Symbol	Min.	Typical	Max	Unit	Ref.
Transmitter						
Optical Wavelength	λ_c	1320	1330	1340	nm	
Side Mode Suppress Ratio	SMSR	30			dB	

Spectral Width(-20dB)	$\Delta\lambda$			1	nm	
Average Output Power	P_{op}	1		5	dBm	1,2
Extinction Ratio	ER	3.5			dB	
Eye Mask		Compliant with IEEE 802.3				
Transmitter and Dispersion Penalty	TDP			3.2	dB	
Average Power of OFF Transmitter				-30	dBm	
Relative Intensity Noise	RIN			-128	dB/Hz	
Receiver						
Average Receiver Power	RSENS			-15	dBm	2,3
Receiver Overload	P_{MAX}			+0.5	dBm	
Centre Wavelength	λ_C	1260		1270	nm	
LOS De-Assert	LOS_D			-15	dBm	
LOS Assert	LOS_A	-30			dBm	
LOS Hysteresis		0.5			dB	

Notes:

1. Output is coupled into a 9/125um SMF.
2. Average Receiver Power (Min) is informative and not the principal indicator of signal strength. A received power below this value cannot be compliant.
3. Measured with a PRBS231-1 test pattern @10.3125Gbps, BER \leq 10⁻¹²

Pin Descriptions

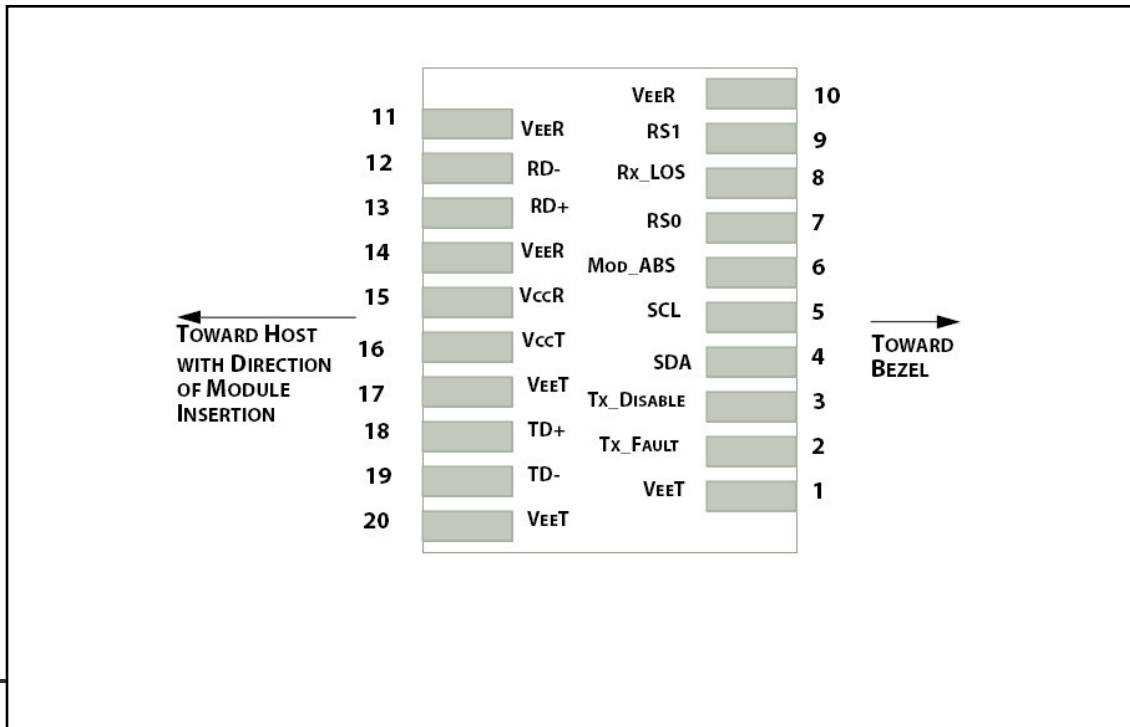

Figure1.Electrical Pin-out Details

Pin	Symbol	Name/Description
1	VEET [1]	Transmitter Ground
2	Tx_FAULT [2]	Transmitter Fault
3	Tx_DIS [3]	Transmitter Disable. Laser output disabled on high or open
4	SDA [2]	2-wire Serial Interface Data Line
5	SCL [2]	2-wire Serial Interface Clock Line
6	MOD_ABS [4]	Module Absent. Grounded within the module
7	RS0 [5]	RS0 for Rate Select: Open or Low = Module supports ≤4.25Gbps High = Module supports 9.95 Gb/s to 10.3125 Gb/s
8	RX_LOS [2]	Loss of Signal indication. Logic 0 indicates normal operation
9	RS1 [5]	No connection required
10	VEER [1]	Receiver Ground
11	VEER [1]	Receiver Ground
12	RD-	Receiver Inverted DATA out. AC Coupled
13	RD+	Receiver DATA out. AC Coupled
14	VEER [1]	Receiver Ground
15	VCCR	Receiver Power Supply
16	VCCT	Transmitter Power Supply
17	VEET [1]	Transmitter Ground
18	TD+	Transmitter DATA in. AC Coupled
19	TD-	Transmitter Inverted DATA in. AC Coupled
20	VEET [1]	Transmitter Ground

Notes:

- [1] Module circuit ground is isolated from module chassis ground within the module.
- [2].should be pulled up with 4.7k – 10k ohms on host board to a voltage between 3.15V and 3.6V.
- [3]Tx_Disable is an input contact with a 4.7 kΩ to 10 kΩ pullup to VccT inside the module.
- [4]Mod_ABS is connected to VeeT or VeeR in the SFP+ module. The host may pull this contact up to Vcc_Host with a resistor in the range 4.7 kΩ to 10 kΩ.Mod_ABS is asserted “High” when the SFP+ module is physically absent from a host slot.
- [5] RS0 and RS1 are module inputs and are pulled low to VeeT with > 30 kΩ resistors in the module.



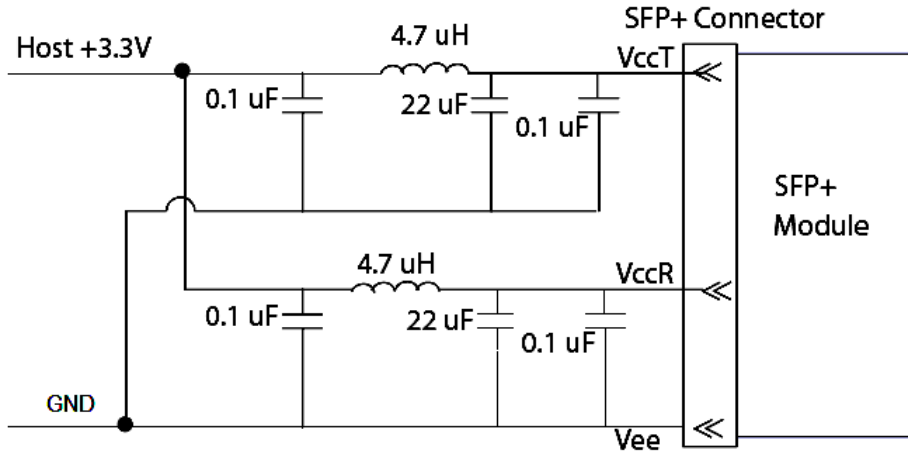

Figure2. Host Board Power Supply Filters Circuit

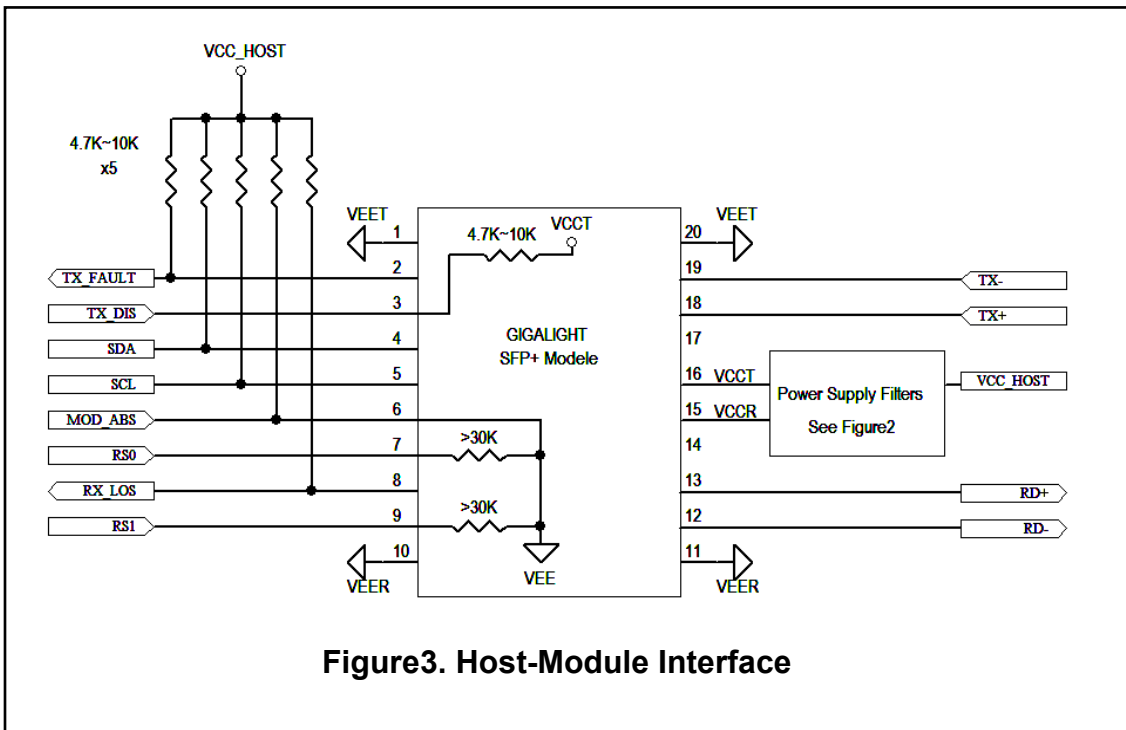

Figure3. Host-Module Interface

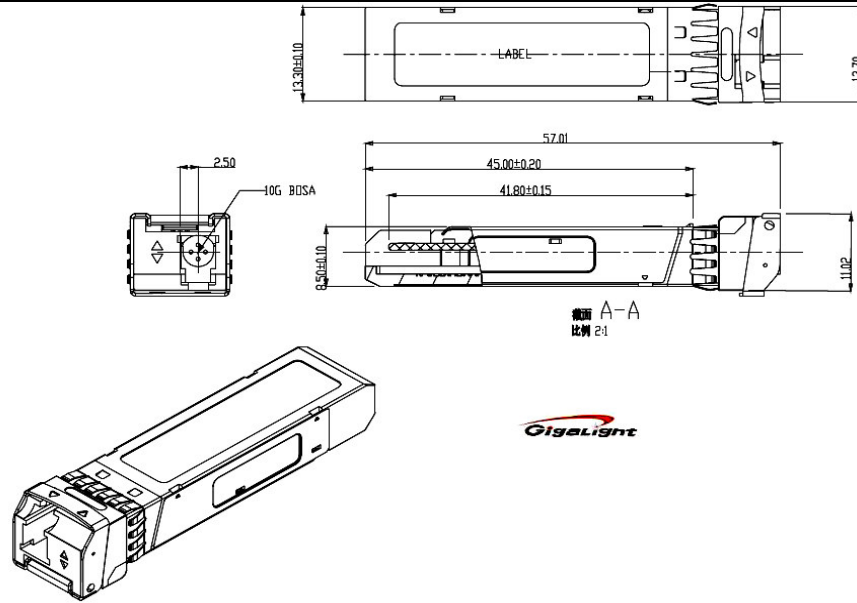

Figure4. Key Mechanical Dimensions

Ordering information

Part Number	Product Description
FBP2733192-ERC	1270nm/1330nm, 10Gbps, 40km, 0°C ~ +70°C
FBP3327192-ERC	1330nm/1270nm, 10Gbps, 40km, 0°C ~ +70°C

Important Notice

Performance figures, data and any illustrative material provided in this data sheet are typical and must be specifically confirmed in writing by FIBERER before they become applicable to any particular order or contract. In accordance with the FIBERER policy of continuous improvement specifications may change without notice.

The publication of information in this data sheet does not imply freedom from patent or other protective rights of FIBERER or others. Further details are available from any FIBERER sales representative.



Fiberer Global Tech Ltd
engineer@fiberer.com

Not only high quality...
www.sfp-module.com

Copyright@ Fiberer Global Tech Ltd.

Our Spiritual Mission

To facilitate User's network and testing systems more successful, let the world more beautiful by our high quality and stability of products and VIP service.

Production Capacity

The quantity of our staff is more than 2,800 and the workshop area is 6,000 square meters. We have a 10,000 level of purifications production workshop about 3000 square meters, and the production capacity is above 5000pcs/week on fiber-optic modules and components.

Email: engineer@fiberer.com

Website: <http://www.sfp-module.com>